



**SOBATI MOTORS**



# **SOBATI MOTORS PRODUCT MANUAL**

[www.sobatimotors.com](http://www.sobatimotors.com)

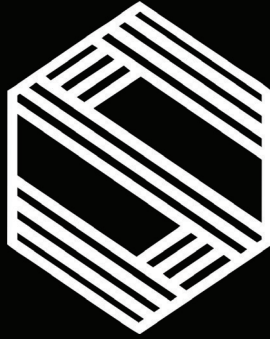

*Sobati Group of companies established since 1946...*

*With over 50 years of combined experience.*

*The Sobati Group is a multi-purpose organization with interests  
in the auto industry, manufacturing, logistics, real estate,  
education and technology with experience and connections in the global markets.*

*From ground up to operations management.*

*the organization consists of highly accomplished logistics, design,  
development, procurement, branding, marketing,  
management and operational services.*

**Chairman of the Board**

**Cam Sobati**

A handwritten signature in white ink, appearing to read 'Cam Sobati', written in a cursive style.



**WHEEL  
LOADERS**

**LOAD CAPACITY:  
0.6 – 6 TONS**



**AUTO  
SELF-LOADING  
CONCRETE  
MIXER TRUCK**

**VALID OUTPUT:  
1.5 – 5 M<sup>3</sup>**

**BACKHOE  
LOADER  
LOAD CAPACITY:  
1–3 TONS**



**INTERNAL  
COMBUSTION  
COUNTERBALANCED  
FORKLIFT TRUCK**

**LOAD CAPACITY:  
2 – 10 TONS**



**ALL-TERRAIN  
FORKLIFTS**

**LOAD CAPACITY:  
1.5 – 5 TONS**



**CRAWLER  
EXCAVATORS**

**OPERATING WEIGHT:  
0.8 – 8 TONS**



**ELECTRICAL  
FORKLIFT**

**LOAD CAPACITY:  
0.5–3.5 TONS**

**WHEEL  
EXCAVATOR**

**OPERATION WEIGHT :  
7–11 TONS**



价值源于可靠  
Value in action

# WHEEL LOADERS

标准版前铲装载机



## ▶ 技术参数 TECHNICAL PARAMETER

Overall Performance/Models			LG12	LG15
General Machine Performance	Operating weight	KGS	2800	3100
	Length	mm	5140	5460
	Width	mm	1600	1800
	Height	mm	2670	2700
	Wheel base	mm	2050	2200
	Wheel track	mm	1350	1400
Bucket Performance	Rated load	KGS	1200	1500
	Standard bucket capacity	m <sup>3</sup>	0.4	0.5
	Bucket width	mm	1580	1800
	Dumping height	mm	2800	3200
	Dumping reach	mm	650	700
	Max. raising height	mm	3750	4010
Engine Performance	model		YUNNEI 490	YUNNEI 490

▶ 相关辅具 AVAILABLE ATTACHMENTS



抓木机 Log Fork



平托叉 Pallet Fork



快换装置 Quick Change (可定制)



抓草机 Grass grapple



扫地机 Sweeper



圆抱夹 Circular Clip



铲斗抱斗2in1 Bucket



搅拌斗 Mixing Bucket

	LG18	LG20	LG25	LG30
	3500	4750	5800	9300
	5600	6200	6600	7200
	1900	2000	2050	2400
	2720	2780	2860	3300
	2250	2400	2780	3150
	1400	1580	1670	2100
	1800	2000	2500	3000
	0.7	0.8	1	1.7
	1900	2000	2000	2400
	3200	3500	3600	3800
	800	900	950	1200
	4030	5000	5300	5600
	YUNNEI 490 Turbo	YUNNEI 4102 Turbo	YUCHAI 4102 Turbo	DONGFANGHONG 6105T/ WEICHAI Deutz

价值源于可靠  
Value in action



Item NO.		H15	H20
Engine Type		Yunnei490 Turbocharging	Yunnei 4102 Turbocharging
Engine power	KW	58	76
Drum Capacity	m <sup>3</sup>	2	3.5
Valid output	m <sup>3</sup>	1.5	2
Overall dimension			
Length*Width*Height	mm	5350*1800*2900	5450*2450*2800
Axle base	mm	2450	2400
Front wheel base	mm	1500	1620
Rear wheel base	mm	1500	1620
Dumping height	mm	1080	1250
Minimum ground clearance	mm	270	280
Total weight(KGS)	KGS	4500	6200
Fuel consumption (Theoretical)L/H	L/H	5.0-7.0	6.0-8.0
Maximum drive speed	KM/H	25	25
Tank rotation speed	Turn/minute	16	16
Tank rotation angle	°	0	180/270
Drive Bridge		small hub reductor	small hub reductor
Gear box		265 splitted	265
Tire Dimensions (Front)		23.5-16	20.5-16
Tire Dimensions (Rear)		23.5-16	20.5-16
Braking distance	mm	1000	1000
Engine oil capacity	L	12-13	13
Hydraulic oil capacity	L	120	120
Hydraulic oil type	L	No.46 efficient wearable	No. 46 efficient wearable
Fuel tank	L	120	120
Water tank	L	500	750
Small pump displacement	L/MINUTE	120	130
Big pump displacement	L/MINUTE	120 (sinking pump)	150
Radius of turning circle		6	6
Bucket capacity	m <sup>3</sup>	0.4	0.6
Transmission oil type/capacity	L	No. 8 transmission oil/21-23	No. 8 transmission oil/50
Axle gear oil type/capacity	L	No. 18 double curve bight/	No. 18 double curve bight/3.5
Hub reduction gear oil type/capacity		No. 18 double curve bight/	No. 18 double curve bight/1.8
Double tire pressure	Bar	/	10
Single tire pressure	Bar	6	6
Tank pressure	Bar	4.0-8.0	4.0-8.0
Brake mode		Disc brake	Disc brake

技术参数

TECHNICAL  
PARAMETER

# AUTO SELF-LOADING CONCRETE MIXER TRUCK

自上料混凝土搅拌车



## 产品细节 PRODUCT DETAILS



H25	H30	H35	H40
Yunnei 4102 Turbocharging	Yuchai 4105 Turbocharging	Yuchai 4105 Turbocharging	Weichai 6105 Turbocharging
76	85	85	92
4	5	5.5	6.5
2.5	3	3.5	4
5450*2450*2800	6150*2700*3350	6150*2700*3350	6650*2860*3350
2400	2450	2450	3200
1620	1680	1680	2000
1620	1680	1680	2000
1250	1400	1400	1500
280	290	290	300
6200	8000	8000	10500
6.0-8.0	8.0-10.0	8.0-10.0	10.0-12.0
25	25	25	30
16	18	18	20
180/270	180/270	180	180/270
small hub reductor	big hub reductor	big hub reductor	ZL-30
265	280	280	315
20.5-16	12R22.5(Double Tire)16/70R20(Single Tire)	12R22.5(Double Tire)16/70R20(Single Tire)	18/70-20
20.5-16	12R22.5or16/70R20	12R22.5or16/70R20	18/70-20
1000	1000	1000	1000
13	13	13	22
120	120	120	150
No. 46 efficient wearable	No. 46 efficient wearable	No. 46 efficient wearable	No. 46 efficient wearable
120	120	120	150
750	750	750	750
130	150	150	150
150	150	150	150
6	6	6	7
0.6	0.6	0.6	0.6
No. 8 transmission oil/50	No. 8 transmission oil/50	No. 8 transmission oil/50	No. 8 transmission oil/50
No. 18 double curve bight/3.5	No. 18 double curve bight/3.5	No. 18 double curve bight/3.5	No. 18 double curve bight/3.5
No. 18 double curve bight/1.8	No. 18 double curve bight/1.8	No. 18 double curve bight/1.8	No. 18 double curve bight/1.8
10	10	10	10
6	6	6	6
4.0-8.0	4.0-8.0	4.0-8.0	4.0-8.0
Disc brake	Disc brake	Disc brake	Disc brake

价值源于可靠  
Value in action

# BACKHOE LOADER

挖掘装载机



## ▶ 技术参数 TECHNICAL PARAMETER

Model	Unit	LGB88	LGB88H	LG15-10BL	LG25-18BL	LG28-20BL	LG30-25BL	LG40-28BL	LG40-30BL
Operating weight	kg	8200	10050	4100	5100	5600	6800	7100	8100
L*W*H	mm	6150×2350 ×3763	6450×2490 ×3120	5900×1860 ×2960	6800×2100 ×2980	6980×2200 ×3100	7600×2250 ×3280	7820×2250 ×3200	7850×2380 ×3580
Loading bucket capacity	m <sup>3</sup>	1.2	1.2	0.5	0.8	1	1.2	1.3	1.5
Rated load	kg	2500	2500	1000	1800	2000	2500	2800	3000
Dumping height	mm	2740	3050	2300	2450	3300	3500	3600	3600
Dumping reach	mm	1062	1048	830	890	910	1050	1065	1065
Digging bucket capacity	m <sup>3</sup>	0.3	0.3	0.1	0.18	0.2	0.3	0.35	0.4
Max. Digging depth	mm	4085	4085	2000	2600	2750	4085	4150	4150



► 相关辅具 AVAILABLE ATTACHMENTS



圆抱夹 round clip



欧式草叉 euro grass fork



平托叉 pallet fork



破碎锤 breaking hammer



扫地机 sweeper



圆包辊 round bale roller

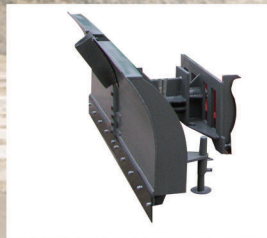

V型推雪板 V snow blade



快换装置 Quick Change (可定制)

► 产品外观尺寸 MACHINE DIMENSIONS

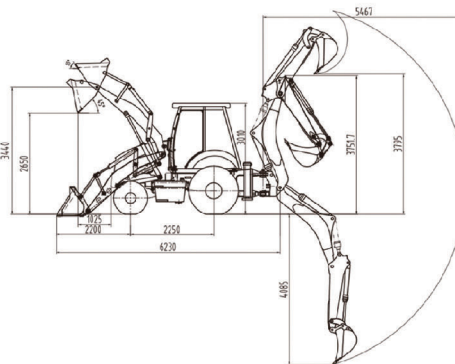

**Advantages:**

- Two sides digging and loading functions
- Various types in different size and loading capacity
- High efficiency hydraulic system
- Premium and standard parameter both available
- Long life working and powerful working capacity

• Options: Cummins 4BTA3.9-C100(74kw); Air conditioner; quick hitch; telescopic boom; H leg

Model	Unit	LGB88	LGB88H	LG15-10BL	LG25-18BL	LG28-20BL	LG30-25BL	LG40-28BL	LG40-30BL
Engine model		Yuchai 4105Turbo	Yuchai 4105Turbo	Yunnei 490	Yunnei 490 T	Yunnei 4100 T	Yunnei 4102 T	Yuchai 4105 T	Yuchai YCD4J22T-125
Rated load	Kw	75	75	42	58	65	76	85	91
Min. Rotation radius	mm	6581	5018	4650	4800	4880	4920	4920	5015
Axle		YUNYU	YUNYU	ISUZU	small hub reduction	Big hub reduction	Big hub reduction	Big hub reduction	Big hub reduction
Driving mode		4x4	4x4	4x4	4x4	4x4	4x4	4x4	4x4
Transmission	Automatic	Power shift	Power shift	Power shift	Power shift	Power shift	Power shift	Power shift	Power shift
Tire size		14-17.5 /19.5L-24	16.9-28-14	20.5/70-16	23.5/70-16	16/70-20	16/70-20	16/70-24	17.5-25

价值源于可靠  
Value in action

# INTERNAL COMBUSTION COUNTERBALANCED FORKLIFT TRUCK

内燃平衡重式叉车



相关辅具  
AVAILABLE  
ATTACHMENTS



抱夹 Holding Clip

## ▶ 产品细节 PRODUCT DETAILS

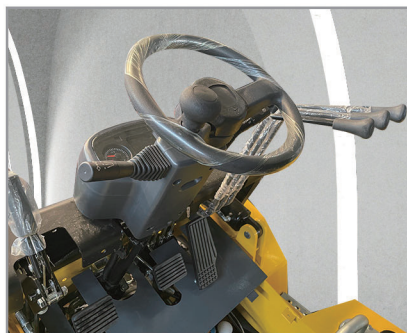

## ▶ 技术参数 TECHNICAL PARAMETER

Paramter	CPC(D)30	CPC(D)35
Fuel type	Diesel	Diesel
Rated load	3000	3500
Load center distance	500	500
Free lifting height	150	160
Total length with fork	3646	3752
Total length without fork	2576	2682
Total width	1170	1225
Overhead guard height	2070	2090
Wheel base	1600	1700
Min. Groud clearance	110	135
Mast tilting angle (front/rear)	6°/12°	6°/12°
Front tire	7.00-12-12PR	28x9-15-12PR
Rear tire	6.00-9-10PR	6.50-10-10PR
Min.turning radius(outer side)	2240	2400
Min. right angle aisle width	3970	4260
Fork dimension	1070*100*45	1070*125*45
Max travel speed (full/free)	17/19	18/19
Max lift speed(full/free)	530/550	440/480
Max. gradeability (full/free)	20/21	15/20
Operating load	3680	4250
Motor	Model	Xinchai C490
		Xinchai C490



叉齿调距器 Fork Gap Regulator

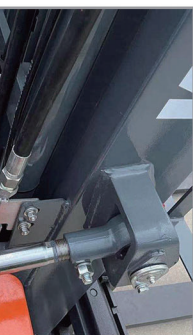

价值源于可靠  
Value in action



## ▶ 技术参数 TECHNICAL PARAMETER

Model	LG15F	LG35F	LG35F
Load Capacity	1500kg	3500kg	
Engine	Yunnei 490/42KW	Yunnei 490/42KW	
Axle	130 bridge weighted steel bridge	Small wheel side weighted cast steel bridge	Small whe
Tyres	Semi-solid 10.00-16	Steel wire tire 20.5/70-16	
Gearbox	265 gearbox	265 double high low speed gearbox	265 doub
Min.turning radius	4600mm	4700mm	
Mast width	148mm	160mm	
Lift height	3000mm	3000mm	
Full-load maximum gradeability	<35°	<35°	
Fork size	1220mm	1220mm	
Frame articulation	Front 200mm, rear 150mm	Front 300mm, rear 250mm	Front
Driving type	Four-wheel drive	Four-wheel drive	
Minimum ground clearance	250mm	250mm	
Front tilt angle	14°	14°	
Mast height	2220mm	2240mm	
Dimension	3100/1300/2300mm	4160/1850/2500mm	

# ALL-TERRAIN FORKLIFTS

全地形叉车



## ▶ 相关辅具 AVAILABLE ATTACHMENTS



铲斗 Bucket



加上抓 Upper Clip



直板抱夹 PSC

## ▶ 产品细节 PRODUCT DETAILS

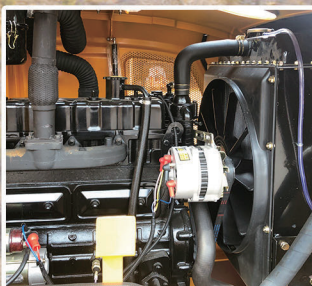

WIDE FIELE OF VIEW	LG45F	LG55F
3500kg	4500kg	5500kg
Yunnei 490/42KW	Yunnei 4100/65KW	Yunnei 4102/76KW
el side weighted cast steel bridge	Middle wheel side weighted cast steel bridge	Big wheel side weighted cast steel bridge
Steel wire tire 20.5/70-16	Steel wire tire 16/70-20	Steel wire tire 16/70-24
le high low speed gearbox	280 double high low speed gearbox	280 double high low speed gearbox
4700mm	4800mm	4800mm
160mm	180mm	180mm
3000mm	3000mm	3000mm
<35°	<35°	<35°
1220mm	1220mm	1220mm
300mm, rear250mm	Front 400mm, rear300mm	Front 500mm, rear300mm
Four-wheel drive	Four-wheel drive	Four-wheel drive
250mm	300mm	300mm
14°	14°	14°
2240mm	2790mm	2790mm
4030/1800/2300mm	4150/1945/2450mm	4150/1945/2450mm

价值源于可靠  
Value in action

# CRAWLER EXCAVATORS

履带式挖掘机



	Parameter	LG10E
▲ Main parameters	Operating weight	900kg
	Overall length	2200mm
	Overall width	930mm
	Overall height	2150mm
	Crawler belt length	1230mm
	Chasis width	930mm
	Standard bucket capacity	0.025m <sup>3</sup>
▲ Main operationrange	Max. digging depth	1630mm
	Max. digging height	2750mm
	Max. dumping height	1960mm
	Max. digging radius	2900mm
	Min. rotation radius	1300mm
	Max. digging distance	2100mm
	Push blade lifting height	180mm
	Push blade fallinig depth	210mm
▲ Main performance specifications	Engine Type	Changchai192FAW/KoopKD192F (Euro V) UppowerKD192F(Euro V)
	Engine parameter	7.6kw-3000rpm /7kw-3000rpm/7.6kw-3000rpm
	Working pressure	16Mpa
	Main pump	6mL/r
	Gradeability	30°
	Max. digging force	10KN
	Operation mode	Mechanical operation

▶ **相关辅具 AVAILABLE ATTACHMENTS**



破碎锤 Breaking Hammer



旋挖钻 Rotary Drilling



松土器 Opener



快换 Quick Hitch



耙子 Rake



筛斗 Screening Bucket



倾斜斗 Tilting Bucket



抓木机 Wood Grapple

▶ **技术参数 TECHNICAL PARAMETER**

LG17E	LG18E	LG20E
1200kg	1855kg	2020kg
2460mm	3750mm	3550mm
1100mm	1050mm	1050mm
2270mm	2300mm	2370mm
1400mm	1620mm	1900mm
1100mm	1050mm	1050-1300mm
0.04m <sup>3</sup>	0.05m <sup>3</sup>	0.05m <sup>3</sup>
2000mm	2200mm	2200mm
3000mm	3660mm	3600mm
2050mm	2520mm	2500mm
3500mm	3770mm	3800mm
1600mm	1500mm	1700mm
2700mm	2660mm	2500mm
180mm	320mm	230mm
200mm	200mm	160mm
Laidong380	ChangchaiZN390Q/Laidong KM385B Xinchai3B11X40(Euro V)	Yanmar3TNV70/KubotaD902(Euro V) EPA
19KW/2200rpm	18Kw-2200rpm/18.1kw-2200rpm/18.5kw-3000rpm	10kw-2200rpm/12kw-2300rpm
18MPa	18Mpa	20Mpa
10+4ml/r	9+9+3ml/r	18ml/r
30°	35°	35°
11KN	12KN	12KN
Pilot hydraulic control	Pilot hydraulic control	Pilot hydraulic control



Model		Unit	CPD750	CPD10F	CPD10E
Power type			Battery	Battery	Battery
Rated load		KG	500-750	800-1000	1000
Load center distance		mm	300	400	400
Driving type			Seat	Seat	Seat
Length	With fork L1		2040	2560	2560
	Without fork L2		1400	1640	1640
Whole Width B			800	800	800
Distance from seat to top light L3			970	970	970
Wheel base L4			860	1020	1020
Front overhang Y			300	300	300
Back overhang L5			290	250	250
Front wheel tread R		mm	700	700	700
Back wheel tread P			668	668	668
Min Floor clearance F			90	90	90
Max lifting height H			2500	3000	3000
Free lifting height H4			80	80	80
Fork adjust size S			703/190	703/190	703/190
Min Turning radius WA			1200	1800	1800
Min Right angle aisle width RA			2800	3400	3400
Frame angle a/β		( ° )	6°/12°	6°/12°	6°/12°
Max lifting speed without goods		mm/s	400	250	250
Max lifting speed with full goods			350	220	220
Max speed without goods		Km/h	13	12	12
Max speed with full goods			12	11	11
Max climbing angle		%	≤ 10	≤ 10	≤ 10
Whole machine weight		Kg	1100	1580	1730
Driving Wheel			2x/2	2x/2	2x/2
Tyre model			Solid tyre	Solid tyre	Solid tyre
Front Tyre			15x4 1/2-8	15x4 1/2-8	15x4 1/2-8
Rear Tyre			3.50-5	3.50-5	3.50-5
Hand Brake			Hydraulic Pedal	Hydraulic Pedal	Hydraulic Pedal
Brake type			M-Hand	M-Hand	M-Hand
Battery Volt/capacity		V/Ah	4X12V/140	12Vx4/160	2X24V/150
Driving motor power		Kw	3.0AC	3.0AC	4.0AC
pump power			3.0DC	3.0DC	3.0DC

## 技术参数

## TECHNICAL PARAMETER







SOBATI MOTORS

# ELECTRICAL FORKLIFT



## 电动重式平衡叉车

CPD15	CPD16	CPD18F	CPD18E	CPD20H	CPD20E	CPD20	CPD25	CPD30	CPD35
Battery	Battery	Battery	Battery	Battery	Battery	Battery	Battery	Battery	Battery
1500	1600	1600-1800	1800	2000	2000	2000	2500	3000	3500
500	500	500	500	500	500	500	500	500	500
Seat	Seat	Seat	Seat	Seat	Seat	Seat	Seat	Seat	Seat
3040	3040	3040	3120	3120	3120	3380	3380	3630	3664
1970	1970	1970	2050	2050	2050	2310	2310	2570	2570
1000	1000	1000	1050	1050	1050	1150	1150	1243	1243
1000	1000	1000	1020	1020	1020	1020	1020	1060	1060
1260	1260	1260	1400	1400	1400	1515	1515	1680	1680
385	350	350	320	320	320	483	483	490	490
365	365	365	330	330	330	400	400	425	425
1010	1010	1010	880	880	880	970	970	1000	1000
100	100	100	830	830	830	950	950	980	980
130	130	130	100	100	100	135	135	135	135
3000	3000	3000	3000	3000	3000	3000	3000	3000	3000
40	40	40	80	80	80	170	170	160	160
1040/200	1040/200	1040/200	925/200	925/200	925/200	1024/200	1024/200	1060/250	1060/250
2100	2100	2100	1950	1950	1950	2050	2050	2200	2500
3850	3850	3850	3400	3400	3400	3760	3760	4100	4100
6/12	6/12	6/12	6°/12°	6°/12°	6°/12°	6°/12°	6°/12°	6°/12°	6°/12°
300	300	300	350	350	350	400	380	450	425
260	260	260	300	300	300	300	280	280	260
14	14	14	15	15	15	15	15	14	14
13	13	13	14	14	14	14	14	12.5	12.5
≤15	≤15	≤15	≤10	≤10	≤10	≤15	≤15	≤15	≤15
2650	2790	2890	2980	3100	3200	4050	4200	4950	5600
2/2	2/2	2/2	2x/2	2x/2	2x/2	2x/2	2x/2	2x/2	2x/2
Solid tyre	Solid tyre	Solid tyre	Solid tyre	Solid tyre	Solid tyre	Solid tyre	Solid tyre	Solid tyre	Solid tyre
18 ×7-10	18 ×7-10	18 ×7-10	18*7-10	18*7-10	18*7-10	7.00-12	7.00-12	28X9-15	28X9-15
16 ×6-8	16 ×6-8	16 ×6-8	18*6-8	18*6-8	18*6-8	18x7-8	18x7-8	18x7-8	18x7-8
Hydraulic Pedal	Hydraulic Pedal	Hydraulic Pedal	Hydraulic Pedal	Hydraulic Pedal	Hydraulic Pedal	Hydraulic Pedal	Hydraulic Pedal	Hydraulic Pedal	Hydraulic Pedal
M-Hand	M-Hand	M-Hand	M-Hand	M-Hand	M-Hand	M-Hand	M-Hand	M-Hand	M-Hand
48V/230	48V/320	48V/320	48/320	48/400	48/400	48/500	48/500	80/500	80/500
6.5AC	6.5AC	6.5AC	7.5AC	7.5AC	7.5AC	11AC	11.0AC	16.6AC	16.6AC
5.5DC	10AC	10AC	10AC	10AC	10AC	12.0AC	12.0AC	13AC	13AC

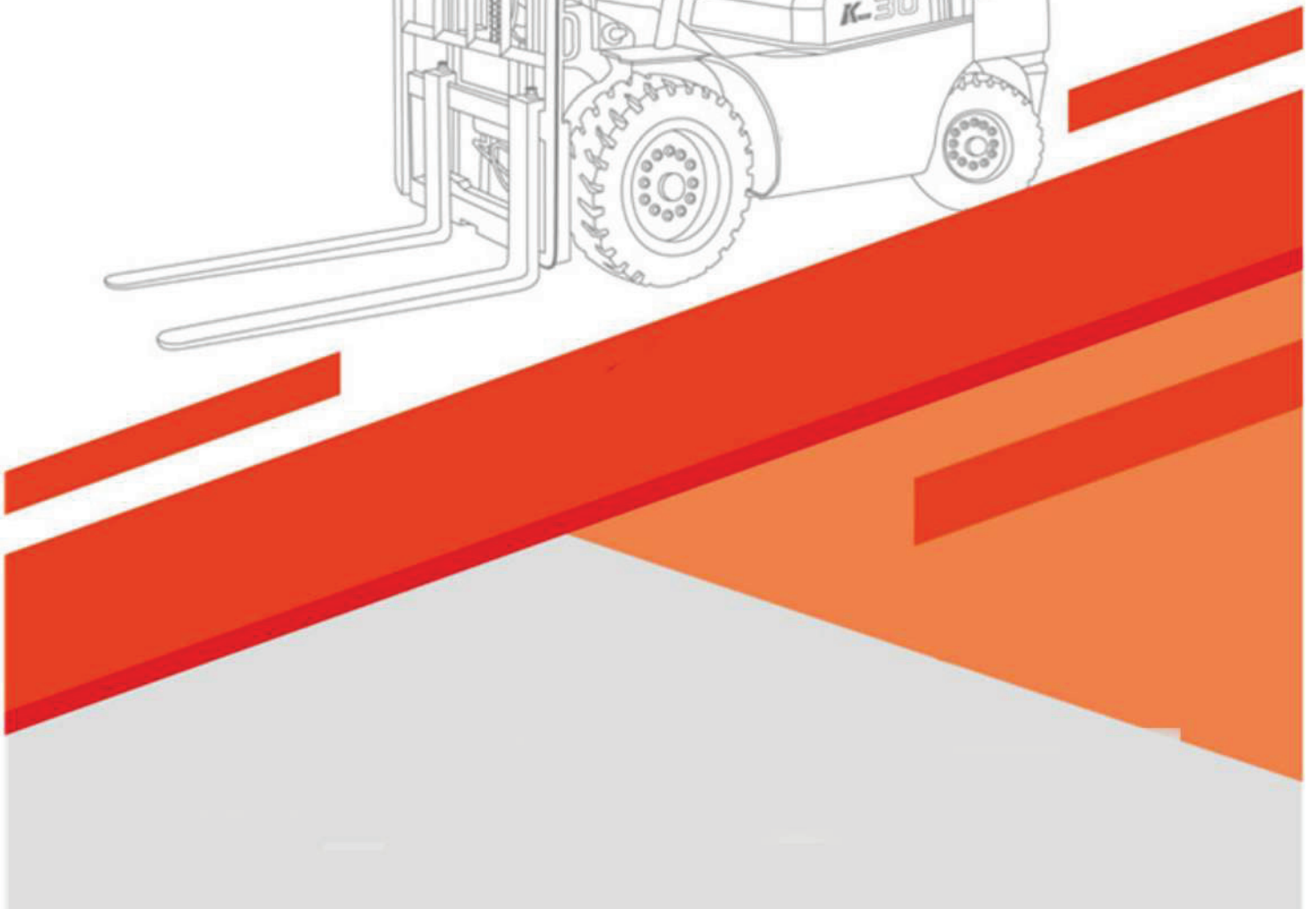



1. Simple appearance, nice figure, strict environmental design;  
2. The new steering wheel adjustment mechanism improves operating comfort and adjustment reliability;  
3. The high-top large-diameter air intake system design can keep the engine away from dust, effectively exert the engine performance and extend the service life;

4. The wide vision mast design makes the driver's vision more open;  
5. Reliable LCD digital special instrument and friendly human-machine interface make it easy for the driver to accurately control the vehicle status;  
6. An optional cast steering axle reduces maintenance costs in the future.

### Main Parameter

型号	Model		CPCD15	CPCD20	CPCD25
额定载重	Rated lifting load	kg	1500	2000	2500
载荷中心距	Load center distance	mm	500		
自由起升高度	Free lifting height	mm	100	150	160
全长(货叉/不带货叉)	overall length(With fork/Without fork)	mm	3180/ 2260	3590/ 2520	3650/ 2580
全宽	Width	mm	1090	1170	
全高(护顶架)	Overhead guard height	mm	2090	2110	2070
轴距	Wheelbase	mm	1400	1600	
最小离地间隙(门架处)	Minimum ground clearance	mm	110		
门架倾角(前/后)	Mast tilt angle (front/rear)	%	6° / 12°		
轮胎尺寸(前)	Tire no.(before)		6.5-10-10PR	7.00x12-12PR	
轮胎尺寸(后)	Tire no.(after)		5.00-8-10PR	6.00x9-10PR	
最小转弯半径(外侧)	Minimum turning radius(outer side)	mm	1950	2300	2240
最小直角通道宽度	Minimum right angle aisle width	mm	3630	3900	3970
货叉尺寸(长x宽x厚)	Fork size	mm	920x 100x 35	1070X100X45	
最高行驶速度(满载/空载)	maximum working speed(Full-load/No-load)	km/h	14/ 15	18/ 20	
最大起升速度(满载/空载)	maximum lifting speed(Full-load/No-load)	mm/s	480/500	500/530	
最大爬坡能力(满载/空载)	maximum gradeability(Full-load/No-load)	%	20/21		
整机重量	Forklift weight	kg	2900	3400	3500
发动机	Engine model		XINCHAI C490	XINCHAI C490	XINCHAI C490

## 3.0-3.8T Internal Combustion Counterbalanced Forklift Truck



1. Simple appearance, nice figure, strict environmental design;  
2. The new steering wheel adjustment mechanism improves operating comfort and adjustment reliability;  
3. The high-top large-diameter air intake system design can keep the engine away from dust, effectively exert the engine performance and extend the service life;

4. The wide vision mast design makes the driver's vision more open;  
5. Reliable LCD digital special instrument and friendly human-machine interface make it easy for the driver to accurately control the vehicle status;  
6. An optional cast steering axle reduces maintenance costs in the future.

### Main Parameter

型号	Model		CPCD30	CPCD35	
额定载重	Rated lifting load	kg	3000	3500	
载荷中心距	Load center distance	mm	500	500	
自由起升高度	Free lifting height	mm	160	160	
全长(货叉/不带货叉)	Overall length(With fork/Without fork)	mm	3930/2690	3930/ 2690	
全宽	Width	mm	1210	1210	
全高(护顶架)	Overhead guard height	mm	2100	2100	
轴距	Wheelbase	mm	1700	1700	
最小离地间隙(门架处)	Minimum ground clearance	mm	110	110	
门架倾角(前后)	Mast tilt angle (front/rear)	%	6° /12°	6° /12°	
轮胎尺寸(前)	Tire no.(front)		28×9-15	28×9-15	
轮胎尺寸(后)	Tire no.(after)		6.5-10	6.5-10	
最小转弯半径(外侧)	Minimum turning radius (outer side)	mm	2240	2240	
最小直角转弯宽度	Minimum right angle asle width	mm	4260	4260	
货叉尺寸(长×宽×厚)	Fork size	mm	1070X125X45	1070X125X50	
最高行驶速度(满载/空载)	maximum workspeed(Full-load/No-load)	km/h	18/20	18/20	
最大起升速度(满载/空载)	maximum lifting speed(Full-load/No-load)	mm/s	485/505	485/505	
最大爬坡能力(满载/空载)	maximum gradeability(Ful-load/No-load)	%	20/21	20/21	
整机重量	Forklift weight	kg	4200	4450	
发动机	Engine model		XINCHAI C490	XINCHAI C490	



1. Simple appearance, nice figure, strict environmental design;
2. The wide vision reinforced mast design makes the driver's vision wider, durable and reliable.;
3. The high-top large-diameter air intake system design can effectively exert the engine performance and extend the service life;
4. The professional and enhanced high-speed gearbox design makes the power more powerful, the operation speed is faster, and the operation efficiency is higher;

5. Integral drawn hood, beautiful appearance and high strength;
6. Equipped with wide-base tires, the tire life is greatly improved and durable;
7. Reliable LCD digital special instrument and friendly human-machine interface make it easy for the driver to accurately control the vehicle status;
8. The new steering wheel adjustment mechanism improves operating comfort and adjustment reliability;

## Main Parameter

型号	Model		CPCD40
额定载重	Rated lifting load	kg	4000
载荷中心距	Load center distance	mm	500
自由起升高度	Free lifting height	mm	150
全长(货叉/不带货叉)	overall length(With fork/Without fork)	mm	4000/ 2930
全宽	Width	mm	1290
全高(护顶架)	Overhead guard height	mm	2180
轴距	Wheelbase	mm	1900
最小离地间隙(门架处)	Minimum ground clearance	mm	140
门架倾角(前/后)	Mas tit angle (front/rear)	%	6°/12°
轮胎尺寸(前)	Tire no.(before)		250-15-16PR
轮胎尺寸(后)	Tire no.(after)		7.00-12-12PR
最小转弯半径(外侧)	Minimum turning radius (outer side)	mm	2710
最小直角通道宽度	Minimum right angle aisle width	mm	4750
货叉尺寸(长×宽×厚)	Forksize	mm	1070× 150× 50
最高行驶速度(满载/空载)	maximum working speed(Full-load/No-load)	km/h	19/ 19
最大起升速度(满载/空载)	maximum lifting speed(Ful-load/No-oad)	mm/s	340/ 380
最大爬坡度(满载/空载)	maximum gradeability(Ful-load/No-load)	%	20/ 21
整机重量	Forklif weight	kg	4950
发动机	Engine model		XINCHAI A495



1.Simple appearance, nice figure, strict environmental design;  
2.The new steering wheel adjustment mechanism improves operating comfort and adjustment reliability;  
3.The high-top large-diameter air intake system design can keep the engine away from dust, effectively exert the engine performance and extend the service life;

4.The wide vision mast design makes the driver's vision more open;  
5.Reliable LCD digital special instrument and friendly human-machine interface make it easy for the driver to accurately control the vehicle status;  
6.An optional cast steering axle reduces maintenance costs in the future.

### Main Parameter

品名	Model		CPCD45
额定载荷	Rated liftng load	kg	4500
载荷中心距	Load center distance	mm	500
自由起升高度	Free lifting height	mm	160
全长(货叉/不带货叉)	overall length(With fork/Without fork)	mm	4120/3050
全宽	Width	mm	1400
全高(护顶架)	Overhead guard height	mm	2230
轴距	Wheelbase	mm	1900
最小离地间隙(门架处)	Minimum ground clearance	mm	150
门架倾角(前/后)	Mast tit angle (frontrear)	%	6° / 12°
轮胎尺寸(前)	Tire no.(front)		300-15-20PR
轮胎尺寸(后)	Tire no.(after)		7.00-12-12PR
最小转弯半径(外侧)	Minimum turning radius (outer side)	mm	2820
最小直角转弯半径	Mnimum right angle aisle width	mm	4830
货叉尺寸(长×宽×厚)	Fork size	mm	1070×150×50
最大行驶速度(满载/空载)	maximum working speed(Ful-load/No-load)	km/h	18/ 19
最大起升速度(满载/空载)	maximum lifting speed(Full-load/No-load	mm/s	420/460
最大爬坡度(满载/空载)	)maximum gradeability(Ful-load/No-load)	%	15/ 20
整机重量	Forklift weight	kg	5860
发动机	Engine model		XINCHAI A498



1. The wide vision mast design makes the driver's vision more open;
2. The high-top large-diameter air intake system design can keep the engine away from dust, effectively exert the engine performance and extend the service life;
3. Reliable LCD digital special instrument and friendly human-machine interface make it easy for the driver to accurately control the vehicle status;
4. Advanced manufacturing technology and high-quality parts ensure high reliability of the vehicle;
5. The smaller front overhang design effectively reduces the load on the front axle under full load, greatly extending the life of the front tires and drive axle;
6. Low noise, small vibration, energy saving and environmental protection;
7. Good appearance, and the outlines are clear.

### Main Parameter

型号	Model		CPCD50	CPCD60	CPCD70
额定载荷	Rated lifting load	kg	5000	6000	7000
载荷中心距	Load center distance	mm	600		
自由起升高度	Free lifting height	mm	210		
全长(货叉/不带货叉)	overall length(Wth fork/Without fork)	mm	4690/ 3510	4720/ 3590	4810/ 3680
全宽	Width	mm	1970		
全高(护顶架)	Overhead guard height	mm	2500		
轴距	Wheelbase	mm	2250		
最小离地间隙(门架处)	Minimum ground clearance	mm	230		
门架倾角(前/后)	Mast tilt angle (front/rear)	%	6° / 12°		
轮胎尺寸(前)	Tire no.(before)		8.25-15-14PR		
轮胎尺寸(后)	Tire no.(after)		8.25-15-14PR		
最小转弯半径(外侧)	Minimum turning radius (outer side)	mm	4080	4120	4180
最小直角通道宽度	Minimum right angle aisle width	mm	5230	5290	5360
货叉尺寸(长×宽×厚)	Fork size	mm	1220× 150× 60		1220× 150× 65
最高行驶速度(满载/空载)	maximum working speed(Full-load/No-load)	km/h	24/ 29	23/ 29	22/ 29
最大起升速度(满载/空载)	maximum lifting speed(Full-load/No-load)	mm/s	510/ 530	500/ 530	500/ 480
最大爬坡度(满载/空载)	maximum gradeability(Full-load/No-load)	%	15/ 20		
整机重量	Forklift weight	kg	8400	8900	9600
发动机	Engine model		XICHAICA6110		



1. Controls designed according to ergonomic principles make operation more comfortable;

2. Optimize the design of the air intake, exhaust, and cooling systems to effectively extend the service life of the engine and improve the reliability of the vehicle;

3. It has a reliable power system and adopts a reliable transmission system, which greatly reduces the failure of the entire machine. At the same time, multiple power auxiliary devices effectively ensure the working reliability of the system;

4. The new steering wheel adjustment mechanism improves operating comfort and adjustment reliability;

5. Reliable LCD digital special instrument and friendly human-machine interface make it easy for the driver to accurately control the vehicle status;

6. Using drum brakes and full hydraulic power braking, the operation is lighter, more comfortable and more reliable;

7. The wide field of view molded slot mast design makes the driver's field of view wider;

8. Good appearance, and the outlines are clear;

9. Advanced manufacturing technology and high-quality parts ensure high reliability of the vehicle;

## Main Parameter

型号	Model		CPCD80	CPCD100
额定载荷	Rated lifting load	kg	8000	1000
载荷中心距	Load center distance	mm	600	
自由起升高度	Free lifting height	mm	200	
全长 (货叉/不带货叉)	overall length (With fork/Without fork)	mm	5175/3955	5497/4277
全宽	Width	mm	2245	
全高 (护顶架)	Overhead guard height	mm	2570	
轴距	Wheelbase	mm	2800	
最小离地间隙 (门架处)	Minimum ground clearance	mm	250	
门架倾角 (前/后)	Mast tilt angle (front/rear)	%	10° /12°	
轮胎尺寸 (前)	Tire no. (before)		9.00-20NHS	
轮胎尺寸 (后)	Tire no. (after)		9.00-20NHS	
最小转弯半径外侧	Minimum turning radius (outer side)	mm	3755	4150
最小直角通道宽度	Minimum right angle aisle width	mm	5755	6010
货叉尺寸 (长x宽x厚)	Fork size	mm	1520 × 170 × 70	1520 × 175 × 85
最高行驶速度 (满载/空载)	maximum working speed (Full-load/No-load)	km/h	20/26	
最大起升速度 (满载/空载)	maximum lifting speed (Full-load/No-load)	mm/s	330/350	
最大爬坡度 (满载/空载)	maximum gradeability (Full-load/No-load)	%	15/20	
整机重量	Forklift weight	kg	11800	12410
发动机	Engine model		XICHA CA6110	





## TAKING A LEADING POSITION IN THE INDUSTRY

Shandong LaiGong Machinery Manufacturing Co., Ltd. established in 1998s, has been well-known as a Chinese leading compact construction machinery manufacturer. The company has been engaged in R&D and manufacturing of construction machinery for more than 20 years with a number of core patents in the field of construction machinery.

As an advanced Group company, LaiGong now have LaiGong International department, LaiGong wheel loader division; LaiGong mixer division; LaiGong excavator division; LaiGong special equipment division; 4 main modern intelligent manufacturing workshops covering total 200,000 square meters area.

Product line includes: Wheel loader, backhoe loader, skid loader, Self-loading mixer, Excavator, wheel excavator, Forklift and Dumper.

LaiGong products have been deeply rooted in the hearts of the people for many years and are trusted by users. Obtained a series of national and international certificates, such as ISO 9001:2008, CE, EPA, EAN etc. With more than 400 domestic sales and service stations and over 40 oversea dealers network, LaiGong has achieved more than 40,000 units sale volume every year, machines are widely exported to global world South East Asia, Middle Asia, Russia, Europe, Africa, South America. Mini loader sales ranks top in domestic market and oversea market.

LaiGong is now improving the whole production process and dedicated to develop machinery which is more suitable for different countries and industrial trends according to customers' feedback.

LaiGong adheres to the business tenet of "excellent quality, integrity-based" and creates value for customers. Shandong LaiGong will build a brilliant prospect with you together.



SOBATI MOTORS

